



DRI-ECO3S-HEAT-HC

3 Storey Whole House Ventilation Unit with
RF Enabled Hall Control and Heating
Installation Manual



1.0 SAFETY INFORMATION

- The provision of the electrical supply and the connection of the unit to the mains must be carried out by a qualified electrician.
- Isolate from power supply before removing any covers. During installation / maintenance ensure all covers are fitted before switching on the mains supply.
- All-pole disconnection from the mains as shown in the wiring diagram must be incorporated within the fixed wiring and shall have a minimum contact separation of 3mm in accordance with latest edition of the wiring regulations.
- This unit must be earthed.
- Ducting must be securely fixed with screws to the spigot(s) to prevent access to live parts. Duct runs terminating close to the fan must be adequately protected by suitable guards.
- If the supply cord is damaged, it must be replaced by the manufacturer, its service agent or similarly qualified persons in order to avoid a hazard.
- Precautions must be taken to avoid the back-flow of gases into the room from the open flue of gas or other fuel-burning appliances.
- This appliance should not be used by children or persons with reduced physical, sensory or mental capabilities or lack of experience and knowledge, unless they have been given supervision or instruction concerning the safe use of the appliance by a person responsible for their safety. Children shall not play with the appliance. Cleaning and user maintenance shall not be carried out by children.
- In order to avoid a hazard due to inadvertent resetting of the thermal cut-out, this appliance must not be supplied through an external switching device, such as a timer, or connected to a circuit that is regularly switched on and off by the utility.
- The heater unit must be connected to the ceiling vent and fan unit using the 3 looms that protrude from the heater module.

1.1 Hazard Symbols



ELECTRIC SHOCK

This unit must be completely electrically isolated before any panels are removed. Check mains supply and control connections.



REFER TO INSTRUCTION MANUAL

Read and understand the installation and maintenance manual before installing, operating or maintaining this product.

1.2 Important Information

This manual contains important information on the safe and appropriate assembly, transport, commissioning, operation, maintenance, disassembly and simple troubleshooting of the product.

While the product has been manufactured according to the accepted rules of current technology, there is still a danger of personal injury or damage to equipment if the following general safety instructions and the warnings contained in these instructions are not complied with.

- **Read these instructions completely and thoroughly before working with the product.**
- **Keep these instructions in a location where they are accessible to all users at all times.**
- **Always include the operating instructions when you pass the product on to third parties.**

1.3 Personal Protective Equipment

The following minimum Personal Protective Equipment (PPE) is recommended when interacting with Nuaire product:

- **Protective Steel Toed Shoes** - when handling heavy objects.
- **Full Finger Gloves (Marigold PU800 or equivalent)** - when handling sheet metal components.
- **Semi Fingerless Gloves (Marigold PU3000 3DO or equivalent)** - when conducting light work on the unit requiring tactile dexterity.
- **Safety Glasses** - when conducting any cleaning/cutting operation or exchanging filters.
- **Reusable Half Mask Respirators** - when replacing filters which have been in contact with normal room or environmental air.

Nuaire would always recommend a site specific risk assessment by a competent person to determine if any additional PPE is required.

2.0 INTRODUCTION

The DRI-ECO3S-HEAT-HC provides whole home ventilation using the Positive Input Ventilation principle. The concept is to introduce fresh, filtered air into the dwelling at a continuous rate, encouraging movement of air from inside to outside. To achieve this the unit is mounted in the loft space, drawing air through the filters and inputting it, at ceiling level, into the property.

The DRI-ECO3S-HEAT-HC fan unit includes an internal sensor to regulate the fan speed according to the temperature of the loft. The internal sensor is to increase airflow to the dwelling when the loft is warmer than the house. The units 'Fixed Temperature Heat Recovery' strategy shall be achieved via a sensor located in the unit and shall improve energy performance accordingly. This unit has all the controls for the fan in the ceiling vent allowing the user to control, programme and monitor the unit from inside the property. A heater incorporating a 400w heating element shall be fitted to the fan unit. It shall be electronically controlled so as to minimise energy use.

A temperature sensor shall be fitted to the outlet of the heater and will control the output of the heater in an attempt to maintain the set point. The set point will be adjustable between 5°C and 15°C. It also has the ability to be controlled using an RF function and can be boosted from a remote wall mounted switch, remote CO2 detector and an RH sensor. Once installed, the airflow can be set to suit the house size and, if required, the way it responds to the temperature changes within.

This appliance can be used by children aged from 8 years and above and persons with reduced physical, sensory or mental capabilities or lack of experience and knowledge if they have been given supervision or instruction concerning use of the appliance in a safe way and understand the hazards involved. Children shall not play with the appliance. Cleaning and user maintenance shall not be made by children without supervision.

3.0 MECHANICAL INSTALLATION

Installation must be completed by competent persons, in accordance with good industry practice and should conform to all governing and statutory bodies i.e. IEE, CIBSE, etc.

Successful operation of the fan depends entirely upon the unit being installed strictly in accordance with these instructions. Please read through this guide in its entirety before commencing installation and follow step by step to ensure a satisfactory completion.

Precautions must be taken to avoid the back-flow of gases into the room from the open flue of gas or other fuel-burning appliances.

3.1 Loft Inspection

Check to ensure that the loft has adequate ventilation. There may be occasions where a loft is so well sealed that additional ventilation may have to be provided by the owner/occupier.

- Ensure** that all water tanks are covered and sealed.
- Check** that all water pipes are lagged.
- Ensure** that any extract fans are discharging to outside and not into the loft.
- Check** that the loft hatch is tightly sealed.
- Ensure** that all holes in the ceilings are sealed i.e. ceiling light fittings etc. A visual inspection of any flues or chimneys for leakage in the loft should be carried out by the installer.
- If any** leakage points are found, or if there is any doubt at all, then the installer should advise the house owner/provider as soon as possible and seek instruction from them before proceeding with the installation.

3.2 Diffuser Installation

3.2.1 Positioning Diffuser

The diffuser has a unique air throw pattern and it is essential that it is located correctly in the central hallway in single storey properties or in the ceiling of the top floor landing on 2 or more storey dwellings.

The diffuser discharges air evenly in all directions along the underside of the ceiling.

Speed Setting	Minimum Distance From Diffuser To Wall
1	100 mm
2	155 mm
3	400 mm
4	625 mm
5	850 mm
6	1000 mm

SMOKE ALARMS -It is also important to ensure that the diffuser is NOT placed within 1 metre of a smoke alarm.

If the diffuser cannot be repositioned, two sides of the diffuser must be closed off using the air dams supplied to encourage the air through the remaining open sides that faces at least 1.5 metres of unobstructed area away from the smoke alarm sensor.

3.2.2 Fitting Air Dams (if required)

Air dams should be fitted, where needed, in order to alter the direction of airflow. Two foam air dams are supplied and will fit on the angled edges of the diffuser to guide airflow away from a smoke detector and/or obstructions.

3.2.3 Fitting Aluminium Diffuser (c/w Intumescent Fireblock)

Using the cardboard template provided, cut an opening in the ceiling and align the top portion of unit (A) above the ceiling over the hole whilst ensuring access to the controls. **The short straight edge of this template is located at a 45° angle to the square sides of the diffuser plates.**

Position the ceiling plate (B) on the ceiling in the room, ensuring the central hole is aligned with the hole in the ceiling and the control location. Use the 4 screws to fix (B) to (A) through the 4 studs positioned on the upper side of (B). Screw bottom part of the unit (C) to the ceiling plate (B) through the plastic spacers and into the 2 studs positioned on the upper side of (A).

Due to the higher air resistance of the fireblock, the speed of the unit should be increased by one increment for the particular property (see 6.1 Speed Setting).

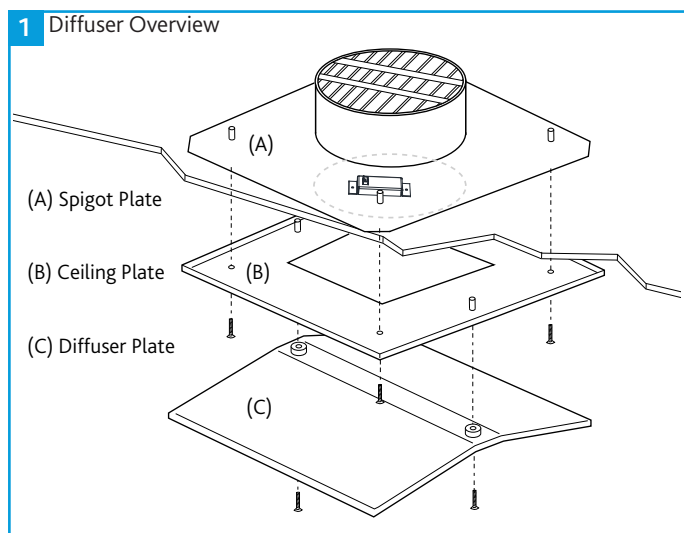

3.3 Heater Installation

The heater unit must be electrically connected to the ceiling vent and fan unit using the 3 looms that protrude from the heater module.

Connect the ceiling vent control loom to the circuit board on the ceiling vent.

Fit the quick release clamp provided onto the ceiling vent spigot.

Insert the heater module into the other side of the clamp and tighten until the metal flanges on the fast clamp meet.

Check that the heater is secure before connecting the interconnect loom into the rear of the fan unit.

Connect the mains power loom into the power outlet on the underside of the fan unit. The flexible duct (maximum length 2m) is connected to the base unit by inserting the duct over the outlet duct and held in place using the supplied cable tie.

Finally when installing the duct to the heater unit insert the duct over the back of the heater, over the four protruding lugs and fasten the cable tie below. This ensures that the duct will be held on securely, check all duct joints are air tight.

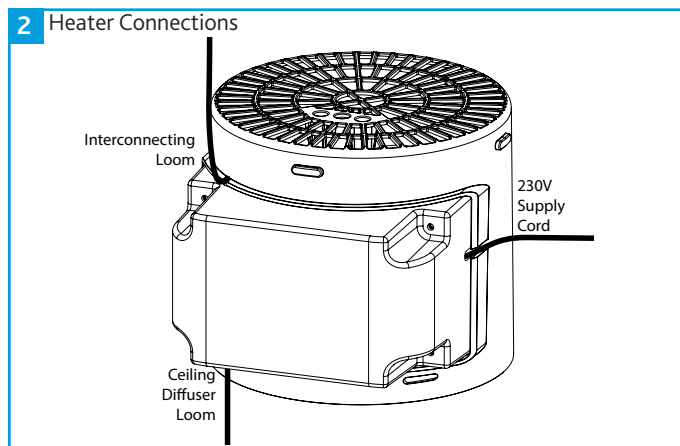

3.4 Filter Installation

The filter has a push fit rim to attach itself to the main body of the unit. Offer the filters up to the unit and apply a small amount of pressure to the filters rim (by hand). The filter will clip into place.

The unit can then be attached to the roof via the cord provided (or fixed to the floor joists using the optional anti vibration mounting kit).

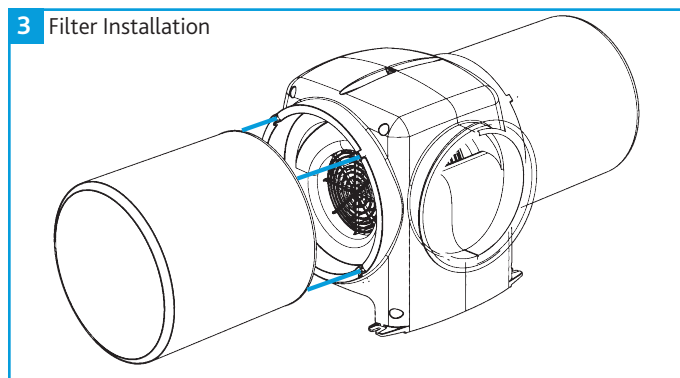

3.5 DRI-ECO3S-HEAT-HC Installation

3.5.1 Joist Hung (Standard Installation)

The standard method of installation is to suspend from a convenient roof beam via the cord supplied (Note: unit weight = 3.5 kg). The method of locating the cord to the roof timber is the responsibility of the installer.

The flexible duct (maximum length 2m) is connected to the fan unit by inserting the duct over the fan outlet and held in place using the supplied cable tie. This method is repeated when connecting the duct to the ceiling vent. Note: Ensure all duct joints are airtight.

The flexible ducting should NOT be installed in a compressive state, as this will negatively impact on the performance of the unit.

4 Example Joist Hung Unit Installation

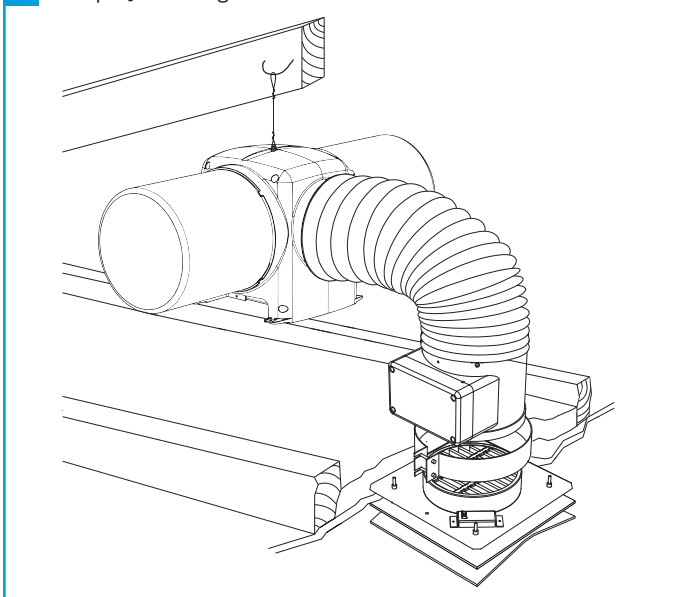

3.5.2 Anti-Vibration Mounting (Optional Mounting)

The AV kit contains all the parts necessary to complete a joist mounted installation. If AV mounting is required, the kit can be purchased direct from Nuair using the following code number: 771393.

Lower the unit with battens (not supplied) attached onto the joists. Mark and drill the 12mm diameter clearance holes required in the ends of the battens.

Place anti-vibration mounts above and below each batten fixing point and, using the 4 large screws and special washers, fix the unit to the joists.

Do not overtighten the fixings. The distance from the top washer to the joist when installed must not be less than 50mm.

5 Anti-Vibration Mounted Unit

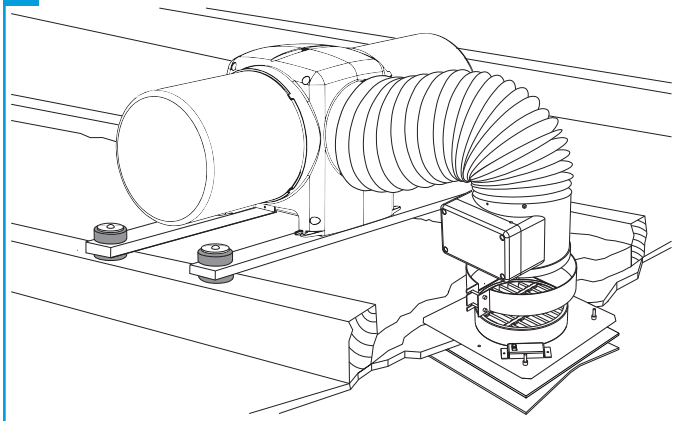

6 Anti-Vibration Mount Detail

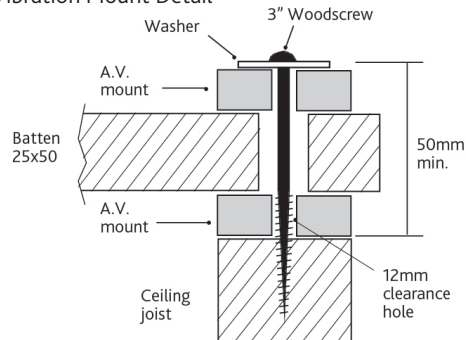

4.0 ELECTRICAL INSTALLATION

Whilst the installation of the unit may be achieved by suitable persons, the provision of the electrical supply and the connection of the unit to the mains must be carried out by a qualified electrician.

Isolate from power supply before removing any covers. During installation/maintenance ensure all covers are fitted before switching on the mains supply.

Disconnection from mains must be incorporated within the fixed wiring and shall have a maximum contact separation of 3mm in accordance with latest edition of the wiring regulations.

In order to avoid a hazard due to inadvertent resetting of the thermal cut-out, this appliance must not be supplied through an external switching device, such as a timer, or connected to a circuit that is regularly switched on and off by the utility.

For good EMC engineering practice, the power supply output cable and any sensor cables should not be placed within 50mm of other cables or each other.

The fan unit is also supplied with a fused spur. The three core mains cable from the unit should be connected to a fixed wiring installation, via the spur, in accordance with current IEE wiring regulations.

4.1 Electrical Information

- Voltage: 230V 1ph 50Hz
- Consumption: 1.6W(min) 15.3W(max) up to 422W with heater at full load.
- Fuse size: 3 Amp

4.2 Wiring Diagram

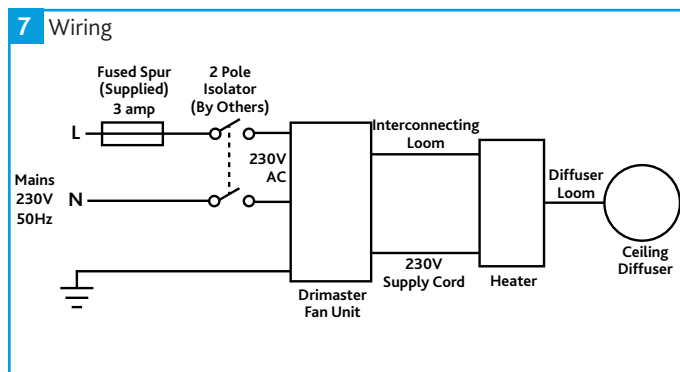

4.3 Replacing Supply Cord

If the mains supply cord to the PSU is damaged, it must be replaced by the manufacturer, its service agent or similarly qualified persons in order to avoid a hazard.

5.0 SMOKE / CARBON MONOXIDE ALARM AUTOMATIC SHUT DOWN

If the unit is required to switch off in the event of smoke/CO detection, alarms are available with separate relay bases from companies such as:

- Kidde – www.kiddesafetysystem.co.uk
- Aico Ltd – www.aico.co.uk

This is a mandatory requirement for all units installed in a 3 Storey property (Building Regulations 2010, Approved Document B Volume 1).

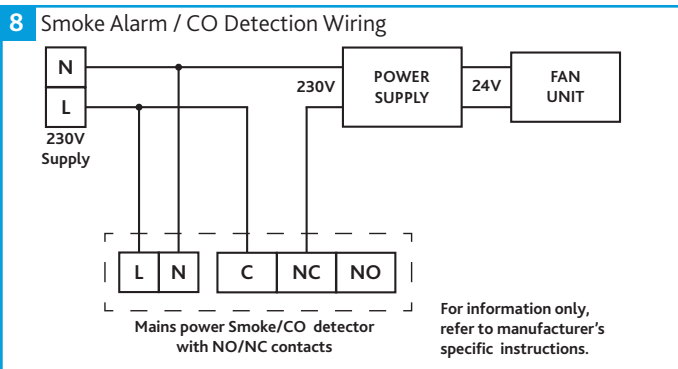

6.4 Setting Temperature Operating Mode

When delivered, the unit is set to temperature operating mode setting of 1 as a default. To change this setting, switch the power to the unit on (via the supplied isolator). The display in the ceiling vent will show the start-up pattern for two minutes and the unit will begin running at speed 6. In this time you can change the temperature setting by pressing and holding the "up" switch. The display will show a flashing value of 1 and will increase every 4 seconds. Once you have reached the temperature setting you require press and release the "down" button to store the setting. The fan will now enter into its normal speed setting mode and a speed can be selected at this point.

9 Diffuser Controls

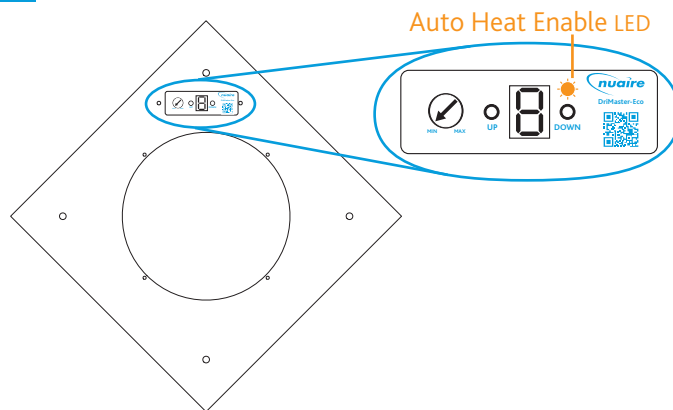

6.0 CONTROLS

In the event of conducted RF interference between 80 to 127 MHz or transient radiated interference between 80 to 87 MHz, the unit may go into standby mode or the LED display may go blank and fan stop temporarily, then go into reset mode (LED flashing with the number of the speed setting) and run at high speed. The unit will return to normal after 2 minutes after the RF interference has stopped.

6.1 Speed Setting

The unit has 5 air flow rate (speed) settings, 1-6. Switches to control the speed settings and the display are located on the underside of the diffuser. The following table shows the flow rates and their corresponding speed settings.

As an example a one bedroom bungalow should be set to speed 2, and a large 5 bedroom detached property would require speed 6.

*At speed 1 the heater will not enable.

Speed Setting	Airflow Rate (l/s)
0	Standby (0)
1	10*
2	20
3	30
4	40
5	50
6	60

6.2 Selecting Speed

When power to the unit is switched on the display will show the temperature control option for 2 minutes. Once the start-up pattern has completed you may now press the "up" or "down" switch to choose the flow rate appropriate to the property you are installing the unit in.

Whilst the unit is in boost or purge mode, the speed setting can not be changed. Alter the sensor setpoint or wait until the boost / purge time has elapsed.

6.3 Setting Thermostat Temperature

A temperature sensor is fitted to the outlet of the heater and will control the heater output to maintain the set point. The set point ranges between 5°C (fully anti-clockwise) and 15°C (fully clockwise) and can be adjusted via the minimum / maximum commissioning pot located on the ceiling vent diffuser. If the temperature at the heater outlet sensor is above the set point, the heater will not activate.

Option	Temperature Operating Mode Description
1 (Default)	At loft temperatures below 19°C the unit will operate on "Normal Operation Mode". At loft temperatures above 18°C but less than 24°C, the unit will switch automatically to "Intelligent Heat Recovery Mode". At loft temperatures above 23°C the unit will switch itself automatically to "Standby Mode".
2	At loft temperatures below 19°C the unit will operate on "Normal Operation Mode". At loft temperatures above 18°C but less than 31°C, the unit will switch automatically to "Intelligent Heat Recovery Mode". At loft temperatures above 30°C the unit will switch itself automatically to "Standby Mode".
3	This option removes the temperature sensing function out of the unit. The unit will operate continuously in "Normal Operation Mode" depending on the volume control setting selected.
4	At loft temperatures below 16°C the unit will operate on "Normal Operation Mode". At loft temperatures above 15°C but less than 28°C, the unit will switch automatically to "Heat Recovery Mode". At loft temperatures above 27°C the unit will switch itself automatically to "Standby Mode".
5	Not applicable for the HEAT model.

7.0 WIRELESS SENSORS & SWITCHES

The Drimaster RF system can simultaneously accommodate one DRI-ECO-RH, one DRI-ECO-CO2 and one switch type, either DRI-ECO-2S or DRI-ECO-4S. **Multiple devices of the same type are not supported.**

7.1 RF Frequency

RF enabled DRI-ECO devices operate at a frequency of 868.3 MHz.

7.2 Installing 4 Way Switch (DRI-ECO-4S)

The switch is provided with an adhesive foam pad to allow quick and easy mounting to the wall. Alternatively the switch may be mounted to the wall using the fixing plate (screws are not provided).

Remove the switch fixing plate by inserting a flat head screwdriver in the rear of the switch on the left or right side, underneath the fixing plate and gently lever up the plate until the fixing lug releases. Repeat for the opposite side. This will give access to the battery compartment on the rear of the PCB and release the fixing plate. Reassemble the remaining components and press into place, an audible click will be heard. 1x CR 2032 battery is provided and expected lifetime is 10 years under normal use.

Normal - If the normal button is used the unit will return to its standard operation programmed at the diffuser.

Boost (Purge) - If the boost button is used, the fan speed will increase to maximum and a 'P' will be shown in the display. Boost is active for 2 hours from when the Boost button is pressed. **Boost mode will not operate if a unit is in standby mode (above 24°C in loft).**

Heater auto - If the heater auto button is used, the heater switches on/off automatically as needed.

Heater off - If the heater off button is used 'Heater auto' will be disabled and the heater switches off.

10 DRI-ECO-4S

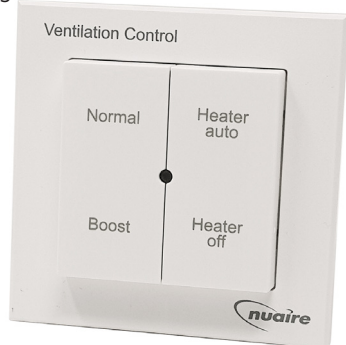

7.3 Installing Humidity Sensor (DRI-ECO-RH)

The front panel of the sensor must first be released by pressing in the plastic fixing lug located on the bottom edge of the sensor. The panel may now be removed and the sensor mounted on the wall in a suitable location (screws not provided). 2x AA batteries are provided.

Boost (Sensor) - If a sensor set point has been exceeded, the fan speed will increase to maximum and a solid 'b' will be shown in the display. Boost mode increases the speed setting by 1. If the unit is running at speed 6, boost is ignored (i.e. A unit is running at speed 3. A boost signal is received from a sensor whereby the speed changes to 4. When the boost condition clears, the unit will revert to speed 3).

11 DRI-ECO-RH

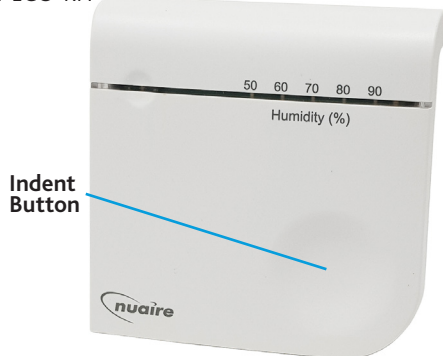

7.4 Installing CO2 Sensor (DRI-ECO-CO2)

The CO2 sensor requires a 230V power supply. Remove the front panel as per the humidity sensor and release the terminal cover via a fixing lug on the rear of the sensor. Refer to the wiring diagram provided and connect the supply to the terminal box. Finally the sensor may be mounted to the wall (screws are not provided).

Boost (Sensor) - If a sensor set point has been exceeded, the fan speed will increase to maximum and a solid 'b' will be shown in the display. Boost mode increases the speed setting by 1. If the unit is running at speed 6, boost is ignored (i.e. A unit is running at speed 3. A boost signal is received from a sensor whereby the speed changes to 4. When the boost condition clears, the unit will revert to speed 3).

12 DRI-ECO-CO2

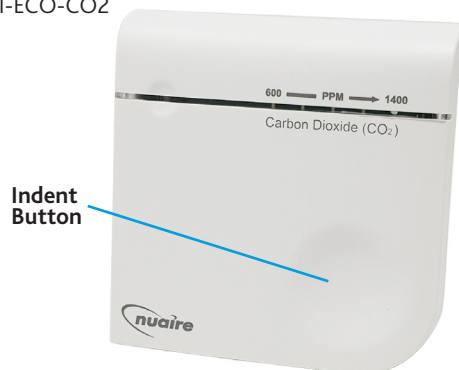

13 DRI-ECO-CO2 Wiring

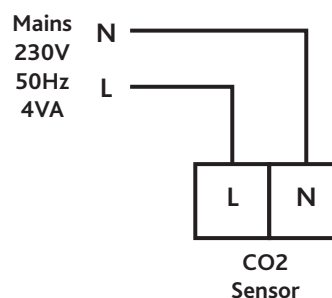

7.5 Unit Binding Mode

Where wireless sensors/switches are present, they must first be bound to the fan unit before it can work. In order to bind to the switches/sensors the fan must be in binding mode. The steps required to enter binding mode are shown below.

1. Ensure the fan unit is powered on.
2. Unit will enter the start-up sequence for 2 minutes when first powered on. Press the down button on the ceiling diffuser control panel once, to exit the start-up sequence.
3. Press and hold both the UP and DOWN buttons for between 20-30 seconds then release (optimum time is 25 seconds), a single horizontal bar on the display flashes.
4. Press "down" to enter binding mode (binding mode last for 5 minutes). The unit will now display a flashing 'b' to indicate it has entered binding mode.

A solid "P" indicates purge, a solid "b" indicates boost, and a flashing "b" indicates binding mode.

7.6 Binding a 4 Way Switch

Once the fan unit is in binding mode a switch may now be bound.

1. Press and hold the 'Boost' & 'Heater off' button for 2-5 seconds.
2. The LED will flash GREEN twice when bound.

To check the binding of a switch, press "boost". A green LED denotes that the switch is bound and the fan should run at full speed. A red LED denotes that the switch is not bound.

if "b" and "P" are flashing on the display, the unit is in binding mode and purge (full speed).

7.7 Binding a Sensor

Putting the unit into binding mode (Section 7.5) before powering the sensors will automatically bind the sensors to the unit. However if they do not bind follow the below steps.

1. Put the unit into binding mode (Section 7.5).
2. Power up sensors (insert batteries for humidity, mains for CO2).
3. Tap indented button then hold until left hand LED flashes red/ green (ignore red/blue and continue to hold). Release button whilst flashing.
4. Tap indented button again, whilst red/green LED is still flashing.
5. Close binding window on fan control panel by holding both "up" and "down" for 5 seconds and release.
6. Check sensor has bound by tapping indented button and look for the left hand LED to go green. If it displays red, repeat from step 1.

7.8 Setting the Sensor Set Point

The sensors will automatically trigger the fan to increase speed once the sensor set point has been exceeded. To change the sensor set point, press and hold the indent button for 5 seconds until the status indication LED flashes BLUE/RED release, the green LED's illuminate to show the current sensor set point. Press the button to cycle through all allowed values, and press and hold for 3 seconds to confirm choice. If the button is not operated for 10 seconds the set point currently selected is stored.

Once the selected sensor set point has been exceeded for longer than the set point delay (10-30 seconds), the fan unit will increase in speed by 1 and a solid 'b' will be shown on the diffuser display.

7.9 Indicator LED's

The sensors and switches include an LED which illuminates when a button is pressed. A green light shows that communication between it and the fan unit is taking place. A red light shows that no communication is taking place and binding may be required.

8.0 HEATER ON (AUTO HEAT) / OFF CONTROL

When the orange LED on the diffuser control panel is illuminated, the heater is active in autoheat mode and is controlled by the temperature setpoint. When the orange LED is not lit, the heater is off. **Heater is enabled only when the orange LED is illuminated.**

9.0 MAINTENANCE

It is important that maintenance checks are recorded and that the schedule is always adhered to, in all cases, the previous report should be referred to.

9.1 Annually

- All electrical terminals within the unit should be tightened.
- Check all earth connections.

9.2 Filter Maintenance

The filters are required to be changed every five years, failure to do so may impair the performance and energy efficiency of this unit. The unit display will show the letter 'C' once 5 years of use has elapsed.

New filters can be purchased direct from Nuair using the following part number: **DRIPOS2001-FILTERKIT** (five year filter). To reset the change filter message, press and hold BOTH "up and "down" button until the letter 'C' starts to flash then release and press the "down" button.

If the units' performance has been reduced dramatically or black dust becomes visible around the outlet diffuser, check that the filter has not become dislodged in any way.

10.0 WARRANTY

The 7 year warranty starts from the day of delivery and includes parts and labour for the first year. The remaining period covers replacement parts only.

This warranty is void if the equipment is modified without authorisation, is incorrectly applied, misused, disassembled, or not installed, commissioned and maintained in accordance with the details contained in this manual and general good practice.

The product warranty applies to the UK mainland and in accordance with Clause 14 of our Conditions of Sale. Customers purchasing from outside of the UK should contact Nuair International Sales office for further details.

Failure to maintain the unit as recommended will invalidate the warranty.

Where a floor/room is more than 4.5m tall, the fan unit must be fitted with a 3 storey aluminium diffuser and requirements in section 5.0 followed.

11.0 END-OF-LIFE AND RECYCLING

Ensure that Nuaire product is made safe from any electrical / water / refrigerant supplies before dismantling commences. This work should only be undertaken by a qualified person in accordance with local authority regulations and guidelines, taking into account all site based risks.

Where possible Nuaire use components which can be largely recycled when the product reaches its end-of-life:

- Fans, motors, controls, actuators, cabling and other electrical components can be segregated into WEEE recycling streams.
- Sheet metal parts, aluminium extrusion, heating/cooling coils and other metallic items can be segregated and fully recycled.
- EPP, plastic ducting, nylon corner pieces, plastic heat exchangers, packaging material and other plastic components can be segregated into mixed plastic and widely recycled.
- Cardboard packaging, wood, used filters and other paper components can be largely recycled or fully processed in energy from waste centres.
- Remaining Items can be further segregated and processed in accordance with the zero waste hierarchy. Please call After Sales Support for further information on items not listed above.

12.0 FREQUENTLY ASKED QUESTIONS

While very rare, issues with newly installed units can occur. Typically these issues can be easily solved by referring to the below table.

Symptom	Cause	Solution
Fan not running.	NO power to the unit (Display is NOT lit).	Ensure unit has not been switched off or that the local fuse has not blown.
	Software error - Power to the unit (Display is lit).	If electricity present, power off, wait and power on again – this may restart the unit.
	Fan failure - Power to the unit ('F' is flashing on display).	Fan has failed and a replacement unit is required.
	High loft temperature.	This is normal, see temperature control options.

13.0 AFTER SALES AND REPLACEMENT PARTS

For technical assistance or further product information, including spare parts and replacement components, please contact the After Sales Department.

If ordering spares please quote the serial number of the unit together with the part number, if the part number is not known please give a full description of the part required. The serial number will be found on the identification plate attached to the unit casing.

Telephone 02920 858 400
aftersales@nuaire.co.uk