

## System 800

## NEWTON 805 NEWLATH

## Damp Proofing Membrane &amp; Plaster Base

Rev 3.0 - 17 August 2016

PRODUCT CODE - M8, M9 &amp; M10

## PRODUCT OVERVIEW

*Newton 805 Newlath is an internally applied, composite damp proofing membrane comprising of high-density polypropylene membrane with a rot-proof polythene mesh heat-welded during the manufacturing process to the surface of one side. The meshed surface creates a mechanical key to allow the membrane to be plastered, rendered or to receive dot & dab plasterboard.*

*Formerly Newlath 2000, 805 Newlath is one of a range of membranes within the Newton System 800 range of damp proofing products. If the meshed surface is not required because the wall finish will be a block wall or timber or metal frame, use [Newton 803](#) instead.*

*Newton 805 Newlath is 1.5mm thick and has a pattern of raised studs linked by reinforcing ribs. The 5mm studs face the wall and create air channels that allow for vapour equalisation to take place between the membrane and the wall.*

*805 Newlath is light, clean and easy to handle. It can be cut with a sharp knife, scissors or shears. The membrane is inert and is highly resistant to water, alkalies, saline solutions and organic acids, and it is not affected by minerals. It is also resistant to bacteria, fungi and other small organisms.*

*Newton 805 Newlath is guaranteed against deterioration for 30 years, has a life expectancy of at least 50 years and is supported by BBA Certification Certificate Number 00/3716.*

## KEY BENEFITS

- Provides a surface that is totally separated and unaffected by the dampness within the wall, ensuring that the wall finish will never be affected by moisture or salts
- Superb 'key' for renders or plasters
- No need to use injected damp proof courses which unnecessarily pump chemicals into the property
- Completely moisture resistant but allows vapour diffusion
- Quick and easy to install
- In some cases, the existing render can be left on the wall
- No requirement for damaging preparation to the wall surface

## TYPICAL APPLICATIONS

- As a damp proof base for renders, plasters or dot & dab plasterboard
- As a damp proofing system to deal with rising damp

## SUITABLE SUBSTRATE - INTERNAL WALLS

- Concrete
- Brick
- Concrete block

## SPECIALIST TOOLS REQUIRED

- High quality SDS drill and drill bits
- A rotating laser level is recommended but not required

## TRAINING AND COMPETENCY OF THE USER

The diagnosis of damp and the specification of correct use of Newton 805 Newlath will, in many cases, require the intervention of a specialist in the field of damp remediation.



## BBA CERTIFICATION

Newton 805 Newlath is supported by BBA Certification Certificate Number 00/3716.



# NEWTON 805 NEWLATH

## Damp Proofing Membrane & Plaster Base

### TECHNICAL DATA

Features	Result	Units	
Material	HDPP		
Colour	White/Translucent		
Density	500	g/m <sup>2</sup>	
Width	1.5 / 1.5 / 2.0	m	
Length	5.0 / 10.0 / 20.0	m	
Area	7.5 / 15 / 40	m <sup>2</sup>	
Stud depth	4.4	mm	
Membrane thickness	1.5	mm	
Vicat softening temperature	148	°C	
Packaged weight	7.95 / 19.00	kg	
Service temperature	-40 to +80	°C	
Installed Performance	Result	Units	Test Method
Thermal conductivity	0.480	W/mK	EN 12667
Water vapour diffusion resistance – Sd value	200	m	BS EN 1931
Water vapour diffusion resistance – μ value	400000	μ	Calculated from SD value
Water vapour diffusion resistance	1000	MNs/g	Calculated from SD value
Resistance to fire	Euroclass E		BS EN 13501-1
Chemical resistance – Excellent	100	%	EN14030
Oxidation resistance – Excellent	100	%	EN ISO 13438

### LIFE EXPECTANCY

When specified, installed and protected in accordance with the Data Sheet and Installation Manual, and fully and permanently isolated from UV light and physical damage or wearing, and only to those substrates confirmed within, Newton 805 Newlath has a service life that can be equal to the design life of the structure.

### PRODUCT WARRANTY

Newton 805 Newlath is supplied with a product warranty of 30 years, and have a life expectancy of at least 50 years (DIN 9001:2000).

### SPECIFICATION

Newton Waterproofing Systems are in partnership with RIBA NBS who publish details of our products and systems within their specification clause library to allow Architects ease of specification through their NBS Plus interface. NBS clauses can be accessed via the technical resources area of the web site where a live NBS Feed is available at [NBS Plus Live Feed](#)

Our website has drawings available for download in [Technical Drawings](#). A selection are also available via [FastrackCAD](#), as well as a range of BIM objects on the [NBS National BIM Library](#)

### COLOUR

Translucent white.

### PACKAGING

- 1.5m x 5m - Product code M8.
- 1.5m x 10m - Product code M9.
- 2.0m x 20m - Product code M10.

### PROTECTION OF THE MEMBRANE

The membrane should always be protected by suitable surface finishes.

Protection methods include:

- Plaster
- Render
- Dot and dabbed plasterboard
- Dot and dabbed ply

**NOTE:** Newton 805 Newlath is Fire Rated to Euroclass E, the same as plastic based insulation. As such the membrane must always be protected from fire by surface finishes, as would be the case with insulation.

# NEWTON 805 NEWLATH

## Damp Proofing Membrane & Plaster Base

### TYPICAL DETAIL

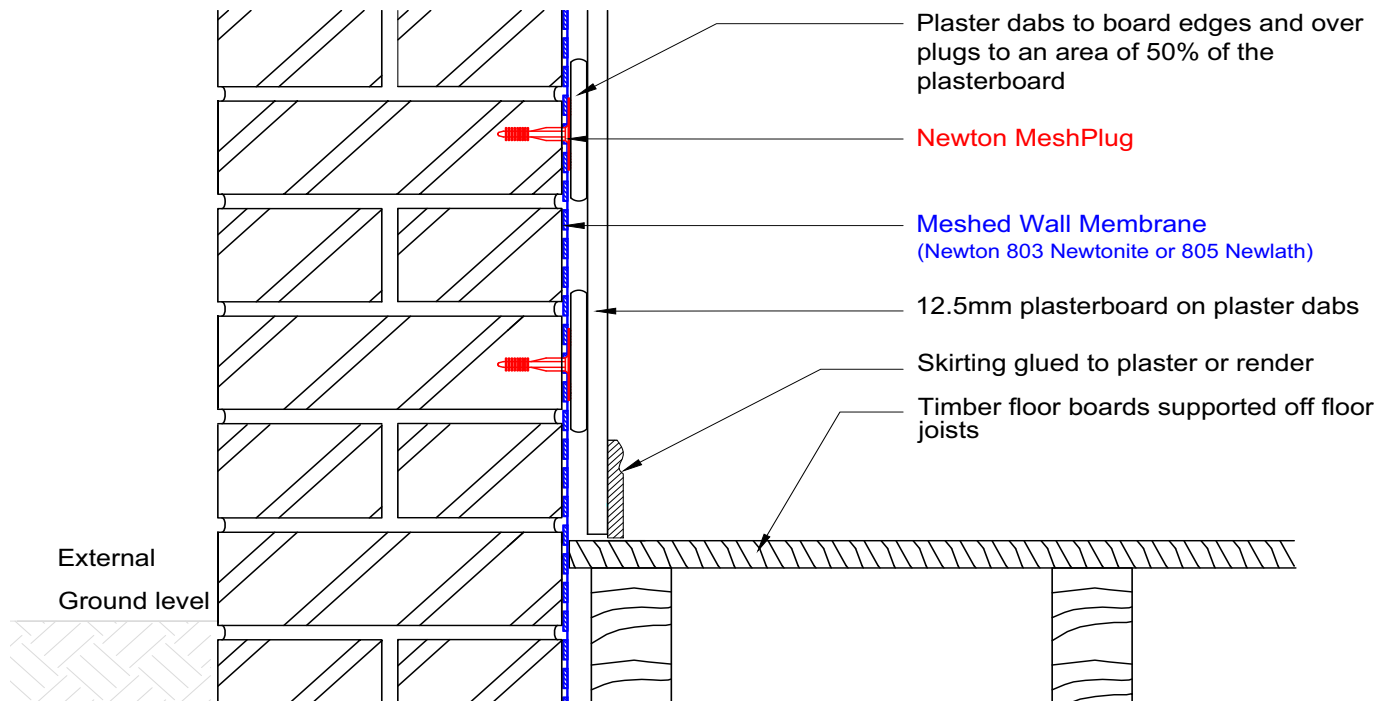

### SURFACE PREPARATION

- Clean the substrate to remove all loose debris and organic matter. Plaster should be removed as it can soften over time, which will weaken the fix of the membrane to the wall. If the wall render is in good condition, it does not have to be removed and the 805 Newlath can be fitted directly over. If the render is damaged, local repairs may be required
- Loose or crumbling render should be removed and local repairs made. If the render is in very poor condition, all of it may need to be removed
- Obtain as flat a surface as possible. If the wall is undulating, better results are produced if the wall surface is dubbed-out flat with sand & cement prior to installation of the membrane rather than dubbing out over the top of the 805 Newlath. A flat, uniform surface to the substrate means that the plaster or render above the 805 Newlath will be uniform also and less likely to have cracking caused by differential thicknesses
- If evidence of bacterial growth can be seen, use a fungicidal product prior to the fitting of the membrane
- If any evidence of wet rot or dry rot is seen, have it dealt with by a qualified remedial specialist
- If a new slab is to be laid as part of the works, it is preferable to fit 805 Newlath prior to the laying of the floor slab with the floor DPM extending upwards in front of the Newton 805 Newlath ready for the concrete placement

### CUTTING TO SIZE

- 805 Newlath can be cut with a sharp utility knife, scissors or shears
- Decide whether the membrane is to be fitted horizontally or vertically

### MEMBRANE JOINTING

- Joints may be made horizontally or vertically
- Joints are created by butt jointing the two edges together and then oversealing the joints with [Newton Mesh Tape](#)
- 805 Newlath can be taken round corners. On particularly difficult shaped corners, cut the 805 Newlath and butt joint and seal as above
- Newton Mesh Tape should be firmly pressed into the mesh of the 805 Newlath to facilitate the joint. In cold and damp conditions a heat gun should be used to gently evaporate surface moisture and then to assist in pressing the Mesh Tape into the mesh of the membrane

### SEALING AROUND PROTRUSIONS

Where the membrane has to be cut around pipes or other protrusions, carefully cut the membrane around the protrusion and then seal around the protrusion with Newton Mastic to ensure there is no bridging between the damp substrate and the new finish.

# NEWTON 805 NEWLATH

## Damp Proofing Membrane & Plaster Base

### FIXING TO THE WALL

- Cut the membrane to size. Ideally, 805 Newlath should be continued up into ceiling voids and down past the slab to the oversite. If this is not possible, cut the membrane so that it finishes tightly to the soffit and floor finish. A gap is not required at the soffit or floor, indeed the system works more efficiently when the system is not ventilated as this impedes the natural vapour drive from inside the property to the outside that still continues through the Newton 805 Newlath
- 805 Newlath is fitted to the wall with the studs facing the wall and the flat meshed surface facing inwards towards the applicator. Fix the membrane to the wall with the [Newton 800 Mesh Plug](#) to all substrates except when fixing to plywood or timber, when a galvanised clout nail should be used, or to slightly friable mortar substrate, when the [Newton 800 Cob Plug](#) should be used
- 805 Newlath can be fitted horizontally or vertically
- Fit the membrane as level as possible - best results are achieved when a long builders level or a rotating laser level is used. Care must be taken to ensure that the 805 Newlath is pulled tight and square while fixing as this will avoid sagging or bulging which can cause problems when plastering or rendering
- Using a 7mm or 8mm drill bit (depending on substrate), drill through the membrane into the wall to a depth of at least 50mm
- Apply a bead of [Newton Mastic](#) around the hole to the membrane so that when the plug is hammered home, the Mastic will seal between the plug and the membrane and so prevent migration of dampness and salting from the substrate to the wall finish
- Use a small number of fixings to initially fit the membrane to the wall as level as possible
- Once the section of membrane is on the wall add the further fixings
- Hammer the plugs home using a wide headed hammer such as a lump hammer or mallet
- A smaller-diameter bit can be used on softer substrate to ensure a tight fit for the plug
- Fixing centres internally must not be greater than 250mm
- On curved or uneven surfaces, closer fixings should be used
- On exposed areas closer fixings are recommended, to restrain possible thermal movement
- Fit 805 Newlath 300mm to return walls to isolate wall finishes from dampness transmitting from the main wall being treated
- 805 Newlath can be taken into reveals
- Fixing should not take place above 30°C and below -5°C.

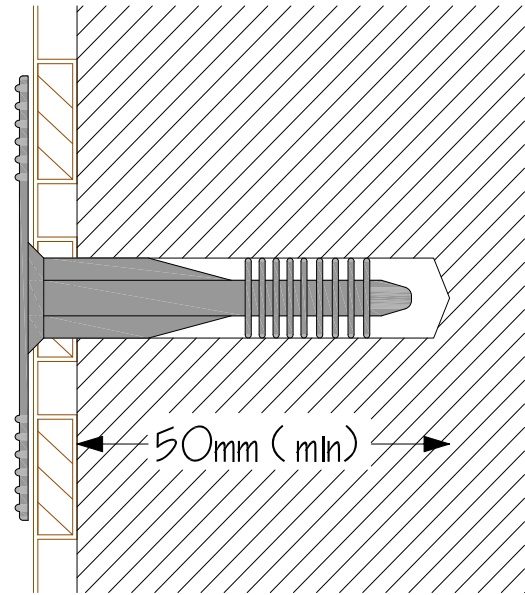

### FINISH (GENERAL)

- 805 Newlath is suitable for wall finishes including plaster, render, hydraulic lime or plasterboard bonded to the membrane with a propriety adhesive compound
- Whilst cement based renders are prone to cracking, careful application can reduce or avoid this. Problems occur when the scratch coat has not been allowed to fully cure prior to the float coat being applied, but the most common problem we see is where the render has not been allowed to fully cure due to accelerated drying. It is extremely important that the render is slowly cured for a period of 7-10 days, longer if possible. The render gets its strength from the chemical processes that take place between the cement content and the added water. The cement needs the correct amount of water to be available to it during the whole of the curing period. If the render dries too quickly due to exposure to sunlight, wind or even dehumidification, the cement will not be able to react with water, producing a weak render that will be prone to cracking
- The render should be dampened regularly during the curing process and protected from accelerated drying with hessian and plastic sheeting
- Hairline cracking can be made good with fine fillers or alternatively a high-build masonry paint can be applied

**DO NOT APPLY DECORATIONS UNTIL PLASTERS OR RENDERS ARE THOROUGHLY DRY.**

### PUNCTURING THE MEMBRANE

If the finished wall is punctured when holes are drilled to fix brackets, etc., Newton Mastic should be inserted before fixing bolts are inserted to ensure no bridging from the damp substrate occurs.

# NEWTON 805 NEWLATH

## Damp Proofing Membrane & Plaster Base

### FINISHING PROFILE

- It is recommended that renders and plasters are raised from the floor by 20-25mm to prevent bridging from the floor. [Newton 800 Finishing Profile](#), available in 2 metre lengths, should be fitted to the bottom of the 805 Newlath as a plaster stop, guaranteeing that the plaster/render will stop short of the floor
- Newton 800 Finishing Profile must be fixed at the same time as 805 Newlath and therefore before the plaster or render is applied
- Newton 800 Finishing Profile is not recommended where the run of wall is uneven or when the membrane is extended down past the slab. Once the finish has been applied and has dried, the 20-25mm gap to the bottom of the plaster/render should be covered by a timber skirting

### PLASTERING

- The recommended plaster for 805 Newlath is Tarmac Whitewall One Coat. Please note that we do not recommend that this product is used in one single coat to Newton Mesh membranes
- The application of the plaster should be in two coats: 6mm scratch coat, 6mm second or float coat
- If a finish coat is required this should be of 3mm
- Tarmac Whitewall should be applied in accordance with good plastering practice as described in BS 8481:2006, BS EN 13914-2:2005
- Always allow 24 hours drying time between coats of plaster. For a high impact resistant finish, use Whitewall High Impact Backing Plaster
- NOTE: Tarmac Whitewall and Tarmac Whitewall High Impact Backing Plaster are not suitable for areas of high humidity and wet areas such as swimming pool surrounds



### RENDERING

- Render with a mix of sand, cement and lime should be applied in two coats using the procedures defined within BS EN 13914-1:2005 to a total thickness of 14mm
- A 3mm skim coat of finishing plaster can be added once the render is fully cured
- The scratch coat should be a mix of 1 part lime: 1 part cement: and 5 parts clean well-graded sharp sand. The second or float coat should be a mix of 1 part lime: 1 part cement: and 6 parts clean well-graded sharp sand. The scratch coat should be 7mm and the second or float coat should be 7mm
- To lessen incidents of cracking, it is best to mix the lime and sand a day or more before use. Cement can then be added at the time of rendering
- The work should be of two coats of render and if required, a third coat of finishing plaster. The purpose of the 7mm scratch coat is to stiffen up the lath and to provide rough and absorbent, backing for subsequent coats
- Work this scratch coat well into the mesh
- Each 7mm coat of render should be allowed to dry for a period of not less than seven, preferably ten days, longer if possible. Cracking may occur if shorter time is allowed between coats
- It is important that the render coats are allowed to cure correctly over the 7 to 10 day period with the render dampened as required. If the scratch coat has not fully cured, slumping of the render can result
- Before applying the second or float coat, carefully drill or scratch out a small section into an area behind the mesh, within the membrane stud, to confirm that it is fully cured. The surface will cure quite quickly but the area behind the mesh must be fully cured also
- In warm periods the render should be protected from excessive drying out by covering with damp hessian sheets and plastic sheeting over it
- Dampen down the scratch coat before application of the float coat
- A smooth finish is not recommended
- Expansion joints should be trowelled in through the render to the membrane. These joints must be filled with a suitable flexible polymer-based sealant
- Expanded metal angle beads and stop beads can be fixed where appropriate using dabs of the same material mixed as for the scratch coat

### FIXING OBJECTS TO THE WALL

Objects should be attached to the wall using resin anchors. Seal around the resin anchor with Newton Mastic.

# NEWTON 805 NEWLATH

## Damp Proofing Membrane & Plaster Base

### HYDRAULIC LIME

- NHL (Natural Hydraulic Lime) 3.5 should be used to a combined depth of 20mm with a 10mm scratch coat and a 10mm second or float coat
- The mix ratio is 2.5 parts sand to 1 part NHL 3.5 mixed as per manufacturers instructions
- The 10mm scratch coat is pushed firmly into the membrane mesh
- Check the application the day after and rub out any cracks
- The surface should be thoroughly scratched without breaking the surface of the mesh
- The scratch coat has to be left for a minimum of 7 days to set. It should be protected from draughts and extremes of temperature
- Before applying the second or float coat, carefully drill or scratch out a small section into an area behind the mesh, within the membrane stud, to confirm that it is set and reasonably hard. The surface will cure quite quickly but the area behind the mesh that has to be set
- The second coat is the float coat and is applied then ruled off to flatten the wall surface. The mix ratio is 2.5 parts sand to 1 part NHL 3.5 mixed as per manufacturers instructions
- The scratch coat has to be dampened down before application of the float coat
- The work has to be protected and tended as per the scratch coat. The second coat is floated or trowelled so a finish coat or a further coat can be applied

### PLASTERBOARD ON DABS

Plaster board panels can be fixed to 805 Newlath by the dot and dab method, giving a dry surface ready for immediate decoration.

'Dabs' should be applied to the heads of the 800 Mesh Plugs, board edges and membrane to cover 50% of the 805 Newlath.

NOTE: We do not recommend that laminated or insulated plasterboard is dot & dabbed to Newton meshed membranes.

Laminated boards have to be fixed to the wall with a mechanical fixing at each side of the board, just above half way up, so that the board does not come apart and block exits during a fire. This is a requirement of UK building code. It is not possible to mechanically fix through the laminated board without puncturing the membrane. If insulation is required to the wall build, use Newton 803, which is not meshed, with an independently supported wall frame.

### COVERAGE

M8: 7.5m<sup>2</sup>.

M9: 15m<sup>2</sup>.

M10: 40m<sup>2</sup>.

Tarmac Whitewall: 1.6m<sup>2</sup> per 25kg bag.

3.5 NHL mixed with sand at 1:2.5 : 3.5m<sup>2</sup> per 25kg bag.

### LIMITATIONS

- Newton 805 Newlath is a damp proofing product for use to above ground (non earth-retaining) structures only. If the wall(s) to be treated have earth to the other side this product is not suitable and our [System 500](#) waterproofing products should be used instead
- Not UV stable
- Fixing to full height to multiple elevations will inhibit vapour drive that naturally moves humidity out of the building. Humidity control systems should be used to control humidity
- Whilst Newton 805 Newlath can be used to deal with penetrating dampness, this should only be considered after building defects such as defective pointing, cracking and defective rainwater goods have been repaired or made good and [Newton 807 BKK eco](#) has been applied to the substrate to prevent the wall taking in rain water

### STORAGE

Newton 805 Newlath should be stored with the rolls standing up on end and away from direct sunlight.

### HEALTH & SAFETY

Product should only be used as directed. Although the 805 Newlath poses no health hazards, usual protective clothing and goggles should be worn in accordance with current health and safety regulations.

We always recommend that the Material Safety Data Sheet (MSDS) is carefully read prior to application of the material. Our recommendations for protective equipment should be strictly adhered to for your personal protection. The MSDS is available upon request from Newton Waterproofing Systems or online via our website. Please see contact details below.

Newton Waterproofing Systems reserve the right to update product literature at any time. Please always refer to our [website](#) for the latest versions.