

DUAL V6 PUMP STATION

The Dual V6 is a packaged pump station designed to collect ground water via a perimeter channel or modular drainage system. It is an upgrade to the standard Dual V3 where higher discharge heads are required.

- Specifically designed for below ground applications.
- A typical application would be for double and triple depth basements or where long discharge runs are required resulting in higher than normal pipe work losses.
- Suitable to collect ground water from 150m² basement that requires a head height over 5m.
- An external surface water area of up to 12m² can be included with the cavity membrane system for drainage.
- The chamber is manufactured from HDPE and able to withstand hydrostatic forces encountered in applications with high water tables.
- Delivered as a complete package including, chamber, all internal pipework and two powerful V6 pumps.
- Designed to be installed by contractors with competent building, plumbing and electrical skills.

This pump station cannot collect grey water from showers and wash hand basins, or foul water from a WC. For this you would require a Foul V3 pump station.

RECOMMENDATIONS

- AlertMaxx2 (AMX2G)
- Hi-PowerMaxx2 (HiPMX2)

SPECIFICATION

- NBS specification R18 (clause 310) Pumping Stations & Pressure Pipelines
- BS 8102:2022 Type C Drainage Protection

PUMP STATION TECHNICAL DATA

Product Code	D V6
Chamber Material	High Density Polyethylene
Volume Below Inlets	137L
Total Volume	273L
Fixed Inlets	3 x 110 / 160mm
Cable Duct Size	50mm
Discharge Connection	2" / 50mm BSP Class C
Discharge Pipework	2" / 50mm BSP Class C
Internal Pipework	1.25" / 32mm BSP Class C
Cable Duct Pipework	2" / 50mm White Waste Pipe



INSTALLATION

The chamber sits on a concrete base, inlets in the form of perimeter channel or modular 110mm system are connected into the chamber, a 50mm pipe discharge connects to the gravity drain and a 50mm cable duct to bring electrics and cabling from the chamber into a dry environment. The chamber is filled with water to prevent buoyancy and is surrounded with concrete. A simple rule of thumb is that the top of the chamber should be level with the structural slab or no deeper than 500mm from the final finishes.

The installation is completed with a double sealed cover supplied by the contractor to tie in with the general floor finish. Remember this product needs to be accessed for service so care should be taken with the location.

For full installation instructions, see 'Dual V4/V6 Installation Instructions' on our website.

DUAL V6 PUMP STATION

DIMENSIONS

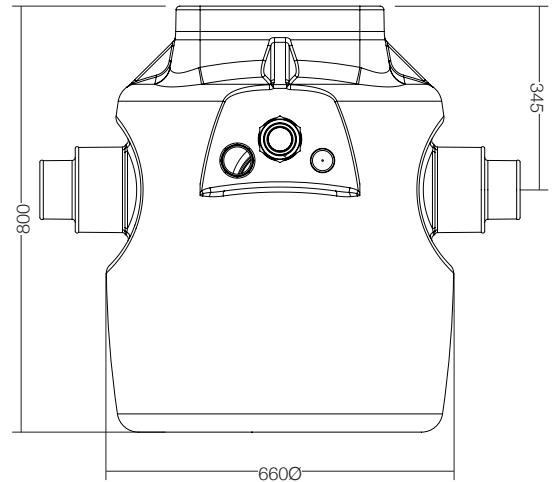
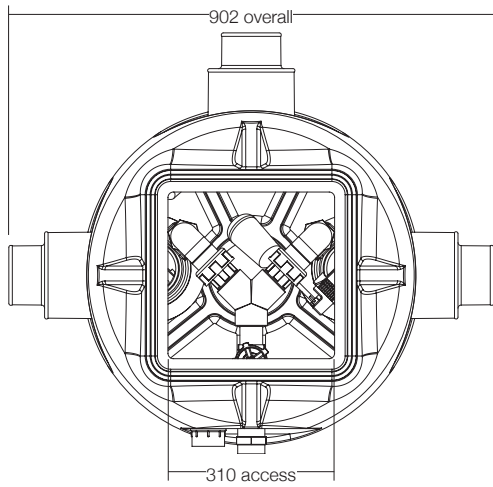

PUMP DATA

Pump Model	V6
Voltage	230V
KW Rating P1 / P2	1.05 / 0.50kW
Full Load Current	4.9A
Fuse Spur Rating	13A Non-switched
Typical Duty	2.0l/s @ 9m
Power Phase	Single
Weight	6.9kg

