



Installation & Commissioning Instructions



PPS/LH PIV

Positive Input Ventilation Unit

220-240V~50Hz

PLEASE READ INSTRUCTIONS IN CONJUNCTION WITH THE ILLUSTRATIONS.
PLEASE SAVE THESE INSTRUCTIONS



Installation and Wiring Instructions for the PPS/LH PIV Unit.



**IMPORTANT:
READ THESE INSTRUCTIONS BEFORE COMMENCING THE INSTALLATION**

SAFETY AND GUIDANCE NOTES

1. DO NOT install this product in areas where the following may be present or occur:
 - 1.1. Excessive oil or a grease laden atmosphere.
 - 1.2. Corrosive or flammable gases, liquids or vapours.
 - 1.3. Ambient temperatures higher than 40°C or less than -5°C.
 - 1.4. Possible obstructions which would hinder access or removal of the Fan.
 - 1.5. Relative humidity above 90%
 - 1.6. Sudden ductwork bends or transformations close to the Unit.
2. All wiring to be in accordance with the current I.E.E. Regulations, or the appropriate standards of your country and MUST be installed by a suitably qualified person.
3. The fan must be provided with a 3A fused, isolator switch capable of disconnecting all poles, having a contact separation of at least 3mm.
4. Ensure that the mains supply (voltage, frequency, and phase) complies with the fan's rating label.
5. The fan should not be used where it is liable to be subjected to direct water spray.
6. This appliance can be used by children aged from 8 years and above and persons with reduced physical, sensory or mental capabilities or lack of experience and knowledge if they have been given supervision or instruction concerning use of the appliance in a safe way and understand the hazards involved. Children shall not play with the appliance. Cleaning and user maintenance shall not be made by children without supervision.
7. Precautions must be taken to avoid the back-flow of gases into the room from the open flue of gas or other fuel-burning appliances.
8. Children of less than 3 years should be kept away unless continuously supervised.
9. Children aged from 3 to 8 years shall only switch on/off the appliance provided the unit is installed as intended for normal operation and they have been given supervision or instruction concerning safe use of the appliance and understand the hazards involved.
10. Children aged 3 to 8 shall not plug in, regulate and clean the appliance or perform user maintenance.

Caution - some parts of this product can become very hot and cause burns. Particular attention has to be given where children and vulnerable people are present.

A. INTRODUCTORY NOTES

The Monsoon PPS/LH PIV is a positive input ventilation unit, designed to be installed in the loft of a dwelling to continually supply filtered fresh air into the building.

The system consists of a fan unit, a heater unit and a diffuser with a short length of flexible ducting.

The Monsoon PPS/LH PIV has two fully adjustable speed settings; 'Trickle' and 'Energy Recovery'. These speeds are set during installation; there are 5 pre-set speeds or an option allowing the speeds to be chosen manually from 10L/s to 60L/s.

The Monsoon PPS/LH PIV uses a sensor to monitor the temperature in the loft, automatically adjusting the air volume when necessary.

'Trickle' speed is automatically selected when the ambient loft temperature is less than 18°C.

'Energy Recovery' is automatically selected when the ambient loft temperature is between 18 and 27°C.

If the ambient loft temperature exceeds 27°C, the Monsoon PPS/LH PIV will automatically switch to standby (no airflow).

For the heater unit, the element is activated by default when the loft air temperature is below 10°C; the system will then work to maintain an input air temperature of 10°C. This temperature threshold can be adjusted between 5°C and 20°C during commissioning.

The heater unit can be installed either to the fan unit or directly to the diffuser spigot.

The unit also incorporates a data logging function. This function will display total runtime of system, time spent in trickle speed, time spent in Energy Recovery speed, approximate energy consumption of the fan and approximate energy consumption of the heater unit. This data is non-resettable.

B. INSTALLATION

TYPICAL INSTALLATION

Fig.1.

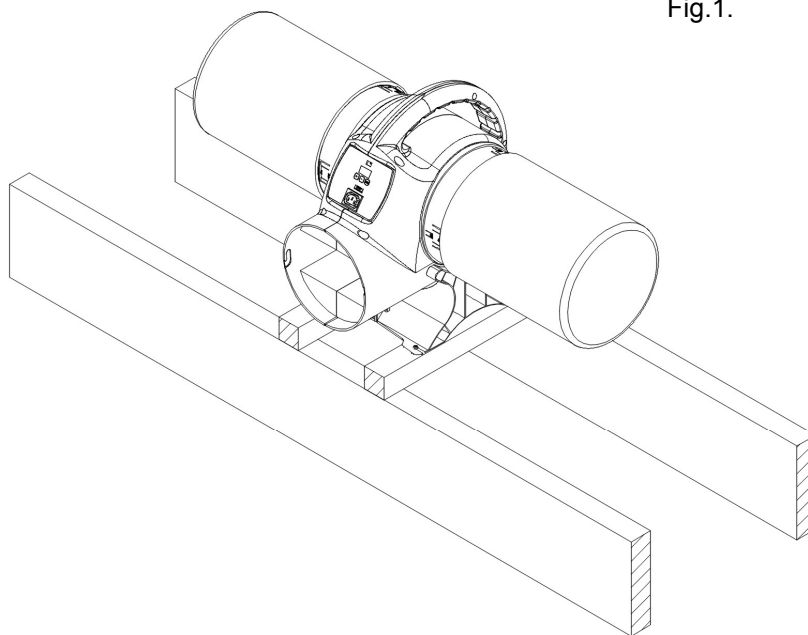

PPS/LH PIV UNIT:

Prior to installation ensure that the loft is adequately ventilated. The following tips can be used as a basis for this. However this is not an exhaustive list.

Ensure that any ridge vents, tile vents and continuous air gaps are not blocked. These may not be present in older properties; however there should be enough 'leakage' to accommodate the requirements of the PPS/LH PIV unit. One method of checking this is by entering the loft, closing the loft hatch, switching off the lights and looking for any daylight penetration. If daylight is visible it is reasonable to assume that there is adequate ventilation within the loft.

There may well be occasions where a loft is so well sealed that additional ventilation may need to be provided by the owner/occupier. This will not only assist the operation of the PPS/LH PIV, but may also help to prevent future expensive structural damage caused by inadequate air movement. It should be noted that there can never be too much ventilation in a loft.

Ensure that all water tanks are covered and sealed.

Check that all water pipes are lagged.

Ensure that any extract fans are discharging to the outside and not into the loft.

Check that the loft hatch is tightly sealed.

Ensure that all holes in the ceilings are sealed, i.e. ceiling light fittings etc.

A visual inspection of any flues or chimneys for leakage in the loft should be carried out by the installer.

If any leakage points are found, or if there is any doubt at all, the installer should advise the house owner/provider as soon as possible and seek instruction from them before proceeding with the installation.

Flexible ducting is supplied as standard. Ensure that this is pulled out and does not allow any moisture to collect; it should be a smooth single curve to the grille. If the application requires a fixed 90 degree bend, straight ducting may be used. See Spares and Accessories on page 12.

Hanging method:

The PPS/LH PIV can be hung from a roof beam (Fig. 2). Fix the screw eye to a convenient roof beam. Use the cord provided to loop through the eye and around the handle on the unit, there are various notches for the cord to run through, tie the two ends together using a suitable knot such as an over hand or fisherman’s knot.

Ensure that the route for the flexible ducting has gentle bends and that the duct cannot be crushed.

Fit the filters to the unit. **Please make sure that the filter is fitted correctly. This will ensure that all the fresh air entering the dwelling has passed through the filter first.**

Ensure that the screw eye is attached to the beam strongly enough and that the beam is in sufficient condition to withstand the load. The unit weight is approximately 4 kg.

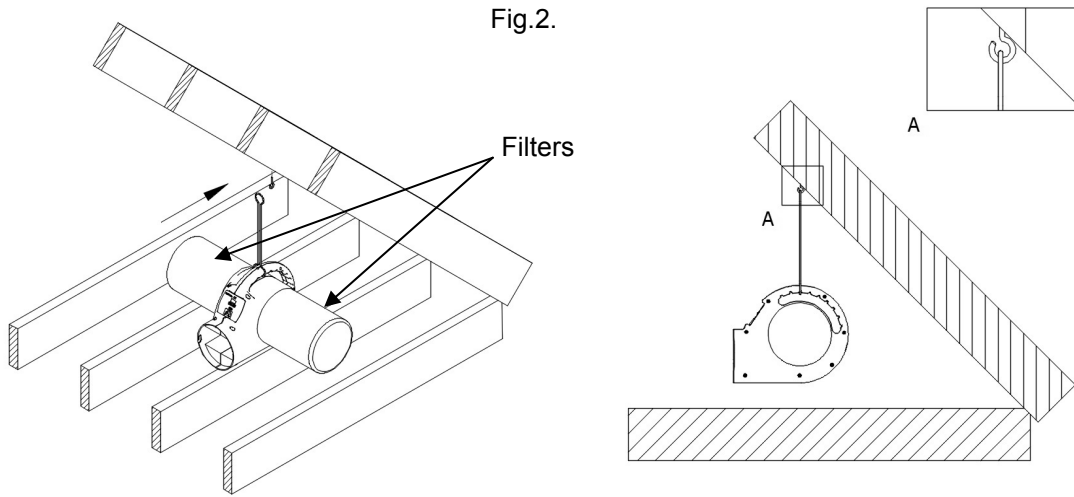

Floor mounting:

Find a suitable location to fix the unit near to where the diffuser is to be located. Ensure that the route for the flexible ducting has gentle bends and that the duct cannot be crushed.

Affix the mounting base to a wooden board or two lengths of timber which can then be screwed to the joists.

Place the unit in the mounting base cradle; two retaining pins hold the unit in place.

Fit the filters to the unit. **Please make sure that the filter is fitted correctly. This will ensure that all the fresh air entering the dwelling has passed through the filter first.**

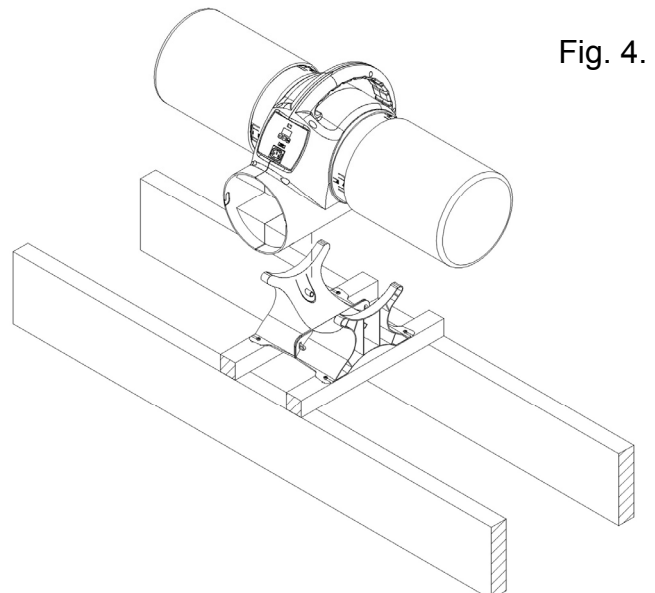
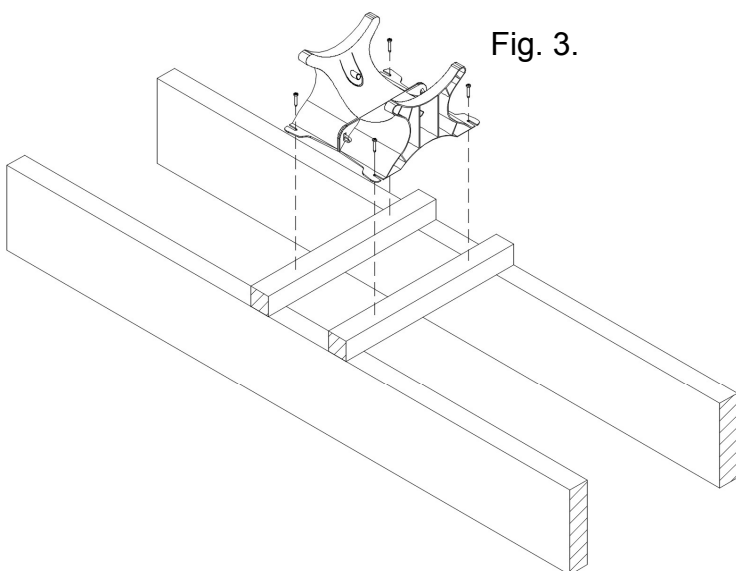

DIFFUSER GRILLE:

The diffuser must be carefully sited to ensure the maximum effectiveness of the system. This grille should be fitted in the ceiling of a common area, ideally above the landing so that the incoming air can reach all the rooms.

Cut the flexible ducting to a suitable length, where possible stretch the ducting to its maximum extent and ensure that there is one continuous smooth bend to the diffuser. The ducting **must** remain a minimum of 1m in length.

Remove the loft insulation from the location of the diffuser and cut a 240-260mm dia hole in the ceiling.

Ensure the four locking tabs are folded in and then push the spigot in to the hole. Holding the diffuser in place; screw the four screws until the locking tabs are holding the diffuser tight against the ceiling (Fig 5). It is important not to over tighten these screws as this may warp the diffuser.

Fit the free end of the flexible ducting to the diffuser spigot using the worm drive clip supplied.

The diffuser should not be situated within 1m of a smoke detector, however if this is not possible the PPS/LH has provisions to blank off the airflow for up to two quadrants of the diffuser. Two blanking plates are provided; these should be pushed on to the support struts inside the diffuser as required (Fig. 6). This should be done before the diffuser is installed in the ceiling as when the screws are tightened down the plates can no longer be removed.

It may also be necessary to use these blanking plates when the diffuser is placed within 1m of a wall, to ensure proper distribution of the supply air blanking plates should be used to direct it away from walls.

Blanking off one side reduces the flow by about 6%, but blanking off two sides reduces the flow by about 20% and so if two sides are blanked off then you should consider increasing the fan speed to maintain the appropriate airflow.

Fig. 5.

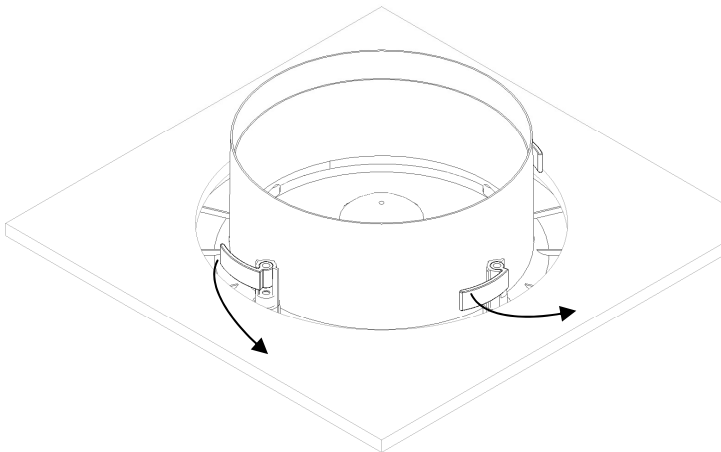
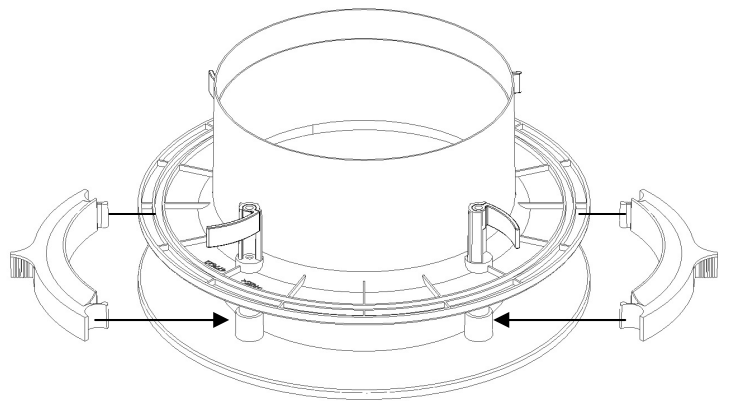

Fig. 6.



Heater Unit

The heater unit can be mounted either to the unit or to the diffuser spigot (Fig. 7), where fitted to the unit there are locating pins that fix the heater to the unit using a bayonet fitting and the locking screw. When fitted at the diffuser end, make sure the direction of the heater is facing the correct way, arrow label on heater must point towards diffuser. The power and sensor cables must be plugged in to the front of the fan unit (Fig 8).

Fig. 7.

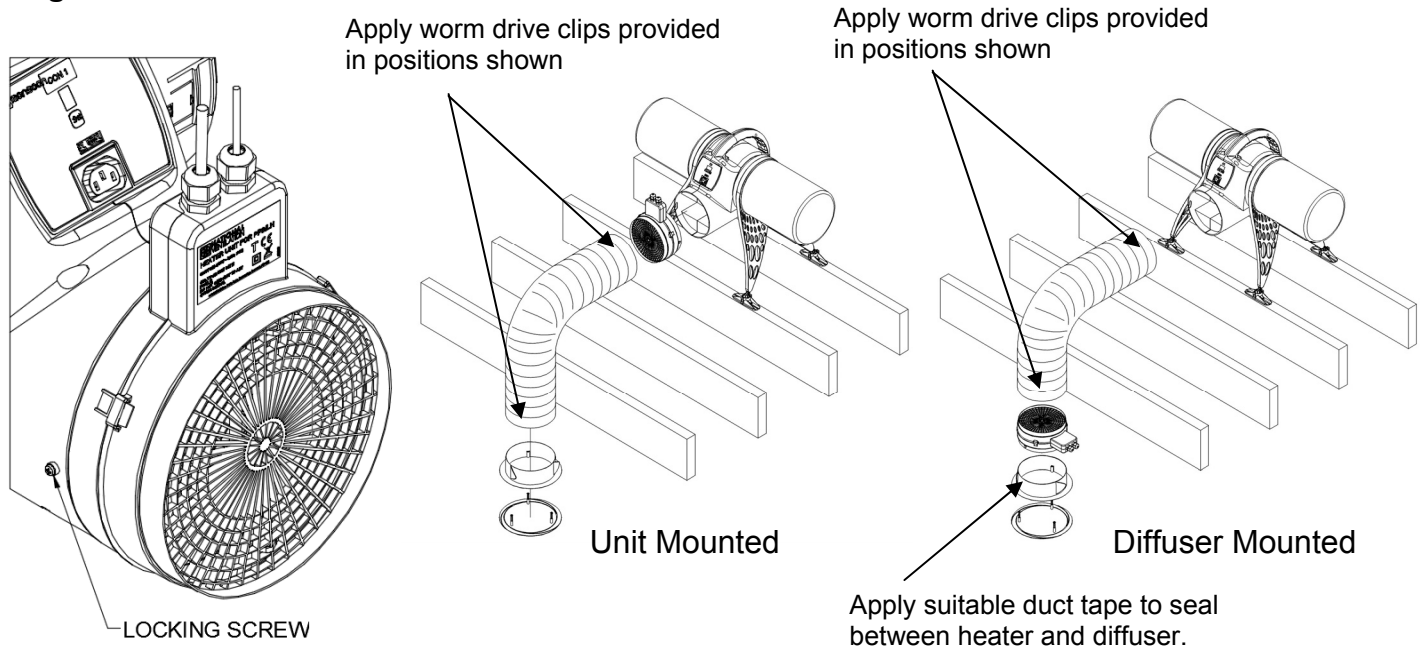

Fig. 8.



C. WIRING



WARNING: THE POSITIVE VENTILATION UNIT AND ANCILLARY CONTROL EQUIPMENT MUST BE ISOLATED FROM THE POWER SUPPLY DURING THE INSTALLATION / OR MAINTENANCE.

A means for disconnection must be incorporated, in the fixed wiring in accordance with the wiring regulations.

Mains supply voltages (220-240V ac) are present in this equipment which may cause death or serious injury by electric shock. Only a qualified electrician or installer should connect the power supply to this unit. The PPS/LH PIV is designed for operation from a single-phase alternating current source (220-240V AC).

A 2m integral mains flying lead is connected to the unit for connection to a 3A switched fused spur. It should be capable of disconnecting all poles, having a contact separation of at least 3mm.

- Ensure the local AC power supply is isolated.
- The product has a pre-wired flying lead. Connect the brown core to Live and the blue core to Neutral.
- Use cable clamps and clips to secure the cable, as appropriate.

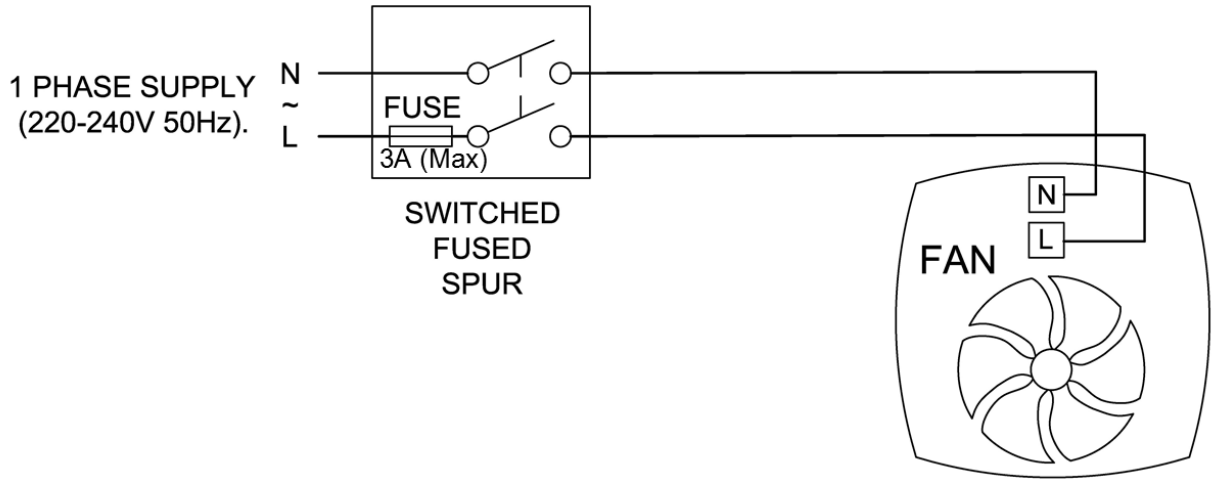

In order to have the product switch off in the event of a fire it must be wired using a smoke alarm with a relay system.

Use Fig.9 as a reference and refer to the instructions provided by the manufacturer of the smoke alarm and relay in order to wire the unit correctly.

Fig.9

FOR REFERENCE ONLY

Smoke Detector with relay

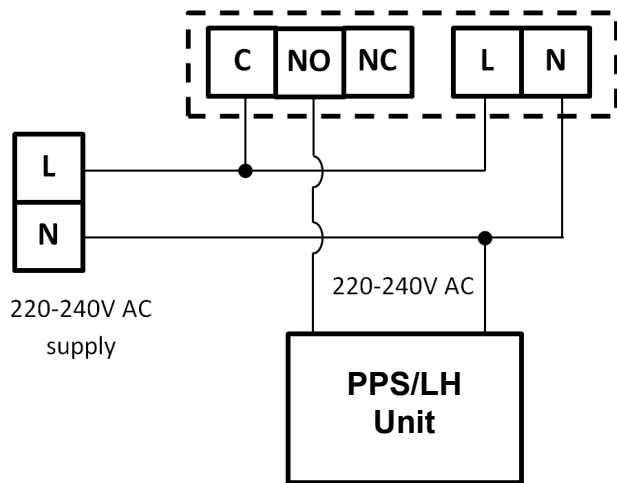

D. START UP SEQUENCE

When the unit is switched on it will first run through a period of system checks. During this time the display will show various system parameters before the fan motor starts. After 10 seconds the product will be ready for commissioning.

E. COMMISSIONING

Accessing the Commissioning Menu

If the fan is powered and the display is not lit then press any button to access the menu. After 30 seconds without menu activity the display will switch off, any changes to the settings will then be applied.

There are three buttons on the front of the unit:

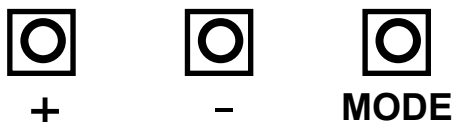

The + button is used to increase the value of a setting, the – button is used to reduce the value of a setting and the Mode button moves to the next menu item.

Lock feature

If the lock feature is enabled; when a button is pressed the display will show, – – –. At this point enter the three digit code by first pressing + or – until the first digit is correct then press MODE to move to the next digit. Repeat until the code is entered and press MODE to enter the commissioning menu. If the code is entered incorrectly, wait until the screen switches off then press any button to begin again.

Air filter

The PPS/LH PIV is provided with G4 filters which are suitable for removing airborne contaminants such as pollen and dust.

Where improved filtration is required optional F7 filters can be used. These filters are effective at removing finer particles such as particulate emissions from diesel engines. In urban areas close to main roads F7 filters are advisable in order to ensure the supply air is clear of these particles which are potentially harmful to health.

Where F7 filters are fitted, please ensure the flow rate of the fan is as expected. F7 filters cause extra system resistance so it may be necessary to increase the fan speed to compensate.

Commissioning Menu Structure

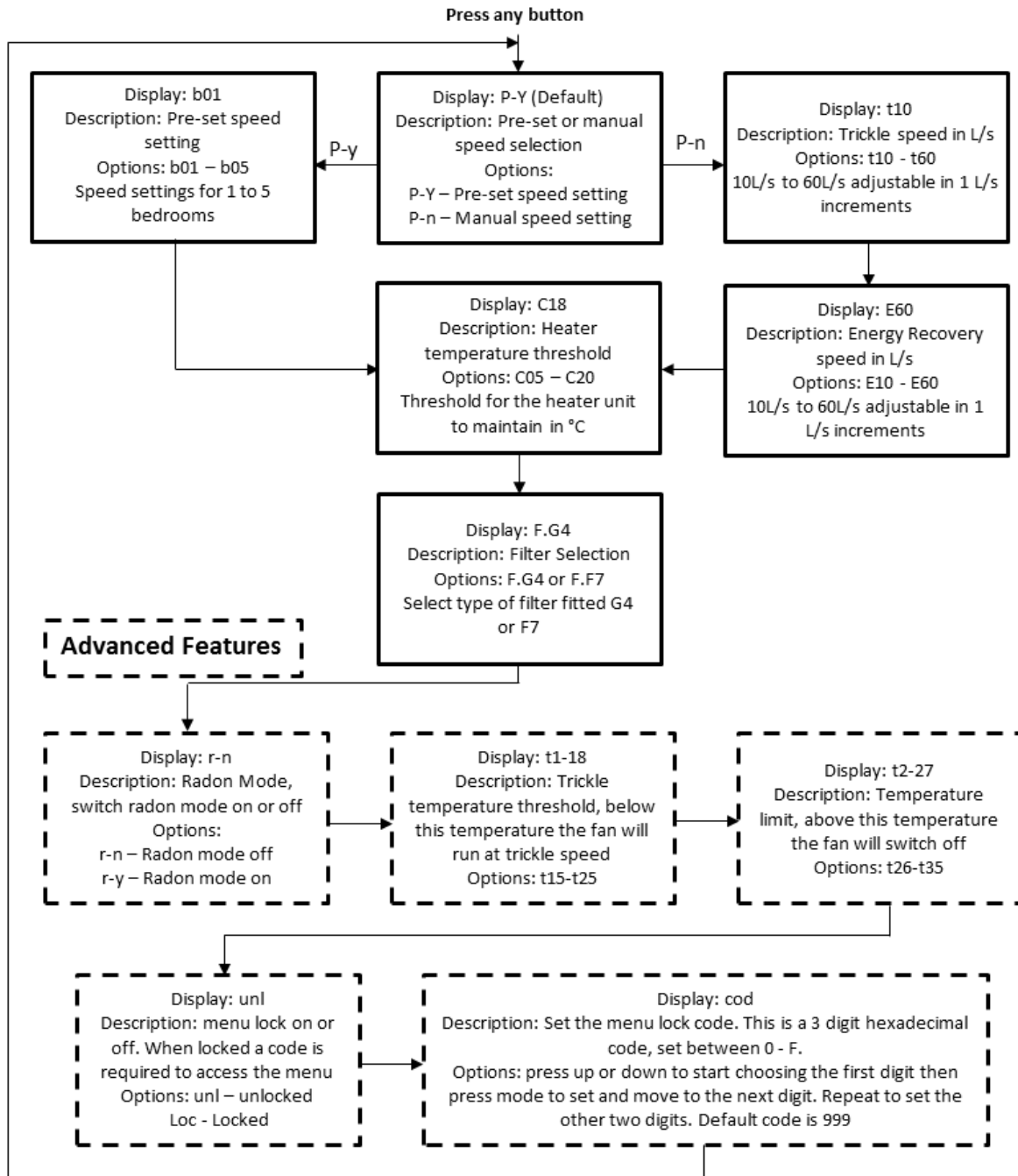

For most installs the standard features allow for ample adjustability, however in some install situations the advanced features will improve the unit's performance or acceptability.

By reducing the **trickle speed threshold** the fan will run at higher speed more often, this would be helpful in a property with persistent damp problems.

Increasing the **temperature limit** will mean the fan will continue to run at higher temperatures, note radon mode being on means the unit will ignore this setting.

The **menu lock** feature will prevent the unit from being adjusted after commissioning as a pass code is required to access the menu. This can be set in the menu to any 3 digit hexadecimal combination.

Speed Settings

The PPS/LH PIV has two speed settings, 'Trickle' and 'Energy Recovery'.

'Trickle' speed is automatically selected when the ambient loft temperature is **below 18°C**.

'Energy Recovery' is automatically selected when the ambient loft temperature is **between 18°C and 27°C**.

If the ambient loft temperature exceeds 27°C, the PPS/LH PIV automatically switches to standby (no airflow).

The speed settings on the PPS/LH PIV are fully adjustable between 10L/s and 60L/s via the manual speed setting option.

Alternatively there are 5 Pre-set speeds, the speed settings relate to the number of bedrooms with, for example, setting b03 being for a three bedroom dwelling. For the approximate flow rates at each setting see Fig.10. The PPS/LH PIV must be set to provide adequate ventilation according to Part F of the building regulations.

Fig.10

No. Bedrooms	Trickle		Energy Recovery	
	L/s	Power (W)	L/s	Power (W)
1	13	2.2	25	3.6
2	17	2.6	31	4.8
3	21	3.2	38	5.5
4	25	3.6	44	7.5
5	29	4.3	50	11.5

The table shows a set up representative of a good low resistance install. When F7 filters and/or a long duct run are used it may be necessary to use the manual speed selection to meet the required flow rate. It is the responsibility of the installer to ensure that appropriate speeds are selected.

F. SERVICING AND MAINTENANCE



WARNING: THE POSITIVE VENTILATION UNIT AND ANCILLARY CONTROL EQUIPMENT MUST BE ISOLATED FROM THE POWER SUPPLY DURING THE INSTALLATION / OR MAINTENANCE.

The fan motor uses sealed ball bearings, and does not require further lubrication.

Apart from filter changes the PPS/LH PIV contains no user serviceable parts.

Under normal conditions; i.e. away from main roads and industrial areas it is recommended that the filter is checked annually and cleaned or replaced as necessary. Otherwise change as required.

The filter may be gently cleaned with a vacuum cleaner or washed in a soapy water solution and allowed to air dry before re-fitting. Do not dry the filter in a tumble dryer. **When re-fitting make sure that the filter is fitted correctly. This will ensure that all the fresh air entering the dwelling has passed through the filter first.**

Accessing Data Logger Menu

To access the menu of data that the unit stores press and hold the mode button for 5 seconds. The menu structure is shown below, press mode to move to the next item:

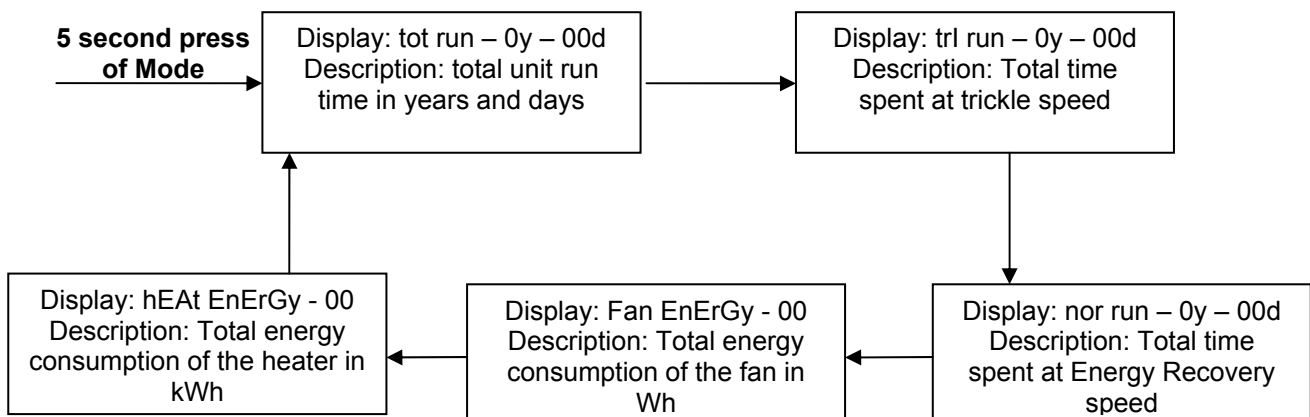

To exit the menu press **MODE** for 5 seconds or wait for the screen to switch off.

Below is a list of spares and accessories available for the PPS/LH unit:

Spares and Accessories	Part Number
F7 FILTER PACK	477957
HEATER UNIT	477876
MOUNTING BASE ASSEMBLY	477749
HANGING KIT	477893
REPLACEMENT G4 FILTER PACK	477891
200mm DIAMETER 2m FLEXIBLE DUCTING	477955
REPLACEMENT DIFFUSER	478228



Disposal

This product should not be disposed of with household waste. Please recycle where facilities exist. Check with your local authority for recycling advice.

National Ventilation
Stathe Road
Burrowbridge
Somerset
TA7 0RY

Contact Information

Website: www.nationalventilation.co.uk
email: info@nvagroup.co.uk
Sales and technical hotline: 01823 690290

EU Authorised Representative: National Ventilation Bedrijvenweg 17 7442 CX Nijverdal Nederland authorisedrep@nationalventilation.nl